



KINEMATICA

Homogenizing perfected.



PILOT PLANT & PRODUCTION

Homogenizing and dispersing technology.

PILOT PLANT & PRODUCTION

Homogenizing and dispersing technology.

The Rotor / Stator principle for dispersing and homogenizing equipment, originally invented by KINEMATICA, has become the worldwide accepted standard for homogenizing and dispersing a solid, fluid or gaseous phase into a fluid phase.

KINEMATICA Rotor / Stator homogenizers successfully process emulsions, suspensions and foams by reducing the size of solid particles, droplets and gas bubbles to a few microns or less. Small and large amounts of product are being dispersed in a more economical, faster and better way than with any other device.

What sets KINEMATICA apart:

- surplus customer value by professional advice - over 40 years of application knowledge and lead quality - ISO 9001 certified
- continuous improvements in the dispersing technology
- cooperational work with scientists from Switzerland, Austria, Germany, China, Japan and USA for specific applications
- excellent quality solutions for dispersing applications in the chemical, biochemical, pharmaceutical, cosmetical and food industry
- leading specialist and manufacturer for homogenizers from lab to pilot plant and production with volumes from 0.05 ml up to 10'000 l and 10 l/min up to 150'000 l/h
- results from the lab can be scaled-up to pilot plant and production
- equipment can be built 100% to customer and product specifications including IQ and OQ

KINEMATICA offers also complete processing systems to customer and product specifications including premix vessels, piping, pumps, stirrers, processing tanks and electronic regulators.

The advantage is to get a whole plant out of one hand and ready-to-plug-in. The different parts will be well suited to customer wishes.

The solution for your homogenizing, dispersing, emulsifying, suspending, size reduction, wet milling, powder induction and foam producing application is offered by KINEMATICA.

For further information, a quotation or a personal demonstration just get in contact with us or fill-in our applications questionnaire on the web and send it back to us.

Our staff will be glad to assist you!

THE RANGE OF PRODUCTS

POLYTRON®

PT / PC-C SERIES

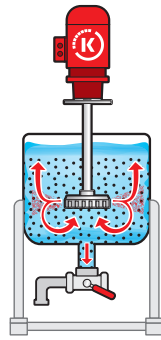

FOR BATCH EMULSIONS / SUSPENSIONS

- Homogenizing, mixing and size reduction of coarse solids into liquid
- Production of emulsions and suspensions with medium to finest droplet and particle sizes
- Wet milling and dispersing of solids, fibers, stringy materials, tissues, cells into fluids and polymers
- High turbulent mixing
- and more

MEGATRON®

MT / MT-V SERIES

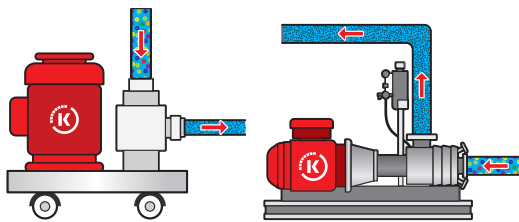

FOR FINEST INLINE EMULSIONS / SUSPENSIONS

- Homogenizing, mixing and size reduction of coarse solids into liquid
- Production of emulsions and suspensions with medium to finest droplet and particle sizes
- Extractions
- Bio-Fuel applications
- Accelerating of reactions
- Gassing of fluids
- De-agglomerations

MEGATRON®

MT-VPC / MT-VPR SERIES

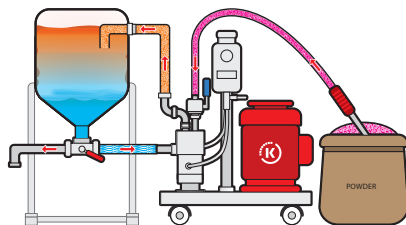

FOR MOST EFFICIENT POWDER INDUCTION

- Powder induction of light to heavy powders
- Powder dispersing
- Suitable for powders used in chemical, pharmaceutical, cosmetic, biochemical and food industries
- and more

MEGATRON®

MT-FM SERIES

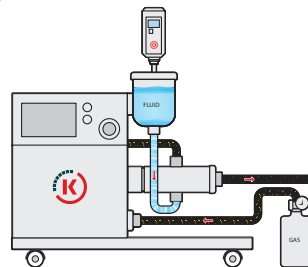

FOR FINEST FOAM DISPERSIONS

- Foamed products with bubble sizes below 20 mm, depending on product
- Foamed protein, dairy products, ice-cream, confectionary, filling products
- Mousse-products
- Technical foams
- Pharmaceutical / medical foams
- Food foams, foamed sauces
- and more

REACTRON®

RT SERIES

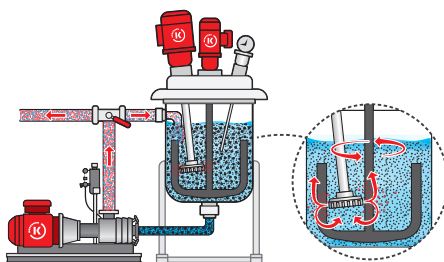

COMPLETE DISPERSING SYSTEMS

- Production of creams, lotions, emulsions
- Pharmaceutical or cosmetic products
- Wet milling and dispersing of solids, fibers, stringy materials, tissues, cells into fluids and polymers
- Extracting of enzymes from bio masses
- and more

POLYTRON® PT machines are batch homogenizing processors. The dispersing aggregate of the machine is immersed in a processing vessel and the product is processed by the rotor/stator dispersing generator.

KINEMATICA offers POLYTRON® pilot plant and production machines with a broad choice of different drive systems, shaft lengths, dispersing generators, stands and processing tanks for different applications and working volumes from a few liters up to several thousand liters.

- Working volumes up to approx. 50 liters (pilot plant) and up to approx. 10'000 liters (production)
- Powerful drive systems including speed regulation
- Standard and special shaft lengths available in CIP design
- Available with mechanical seal systems for pressure and vacuum applications
- ATEX (EX-Proof) versions can be supplied
- Dispersing generators for wide range of working volumes and homogenizing performance; also BIOTRONA® flash blender and dissolver available
- Product wetted parts made from high alloyed stainless steel
- Clamp, flange or customer specific vessel connection can be supplied to connect the machine to the process vessel
- Different stand models - also moveable - with electric, pneumatic or hydraulic stroke deliverable
- Process control can be designed and supplied
- Greatest possible flexibility to reach the application goal

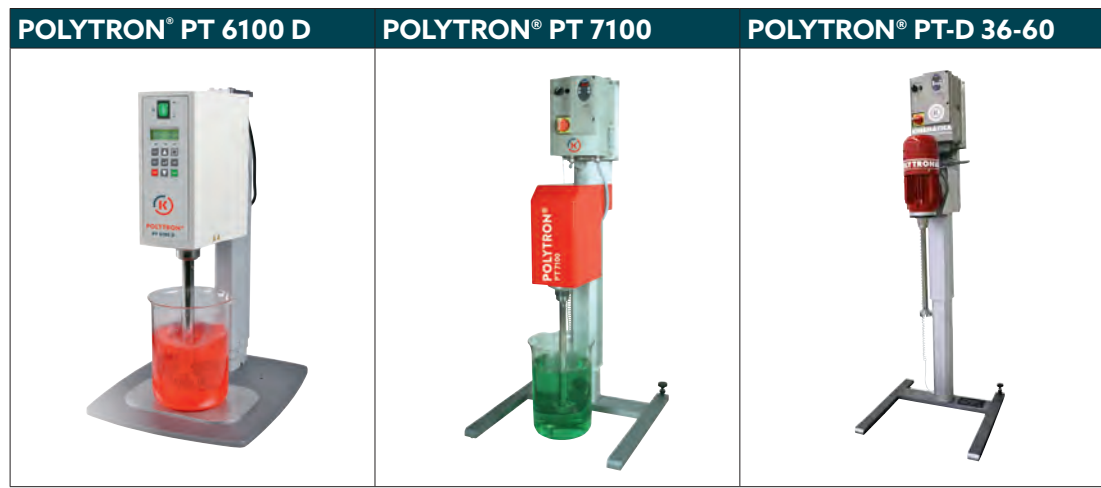

Model / Series	for volumes up to	tip speed max.	rpm max.	Ø generator	standard Shaft length	Power	Further Description, Options (see below)
PT 6100 D	30 l	34 m/s	24'000 rpm	36-60 mm	250 mm	1700 / 800 W	1,3,6,7,8,11,12
PT 7100	40 l	34 m/s	12'000 rpm	36-60 mm	400 mm	1.5 kW	1,3,6,7,8,11,12
PT-D 36-60	50 l	34 m/s	12'000 rpm	36-60 mm	400 mm	up to 3.0 kW	1,4,5,7,8,10,11,12
PT(-C) 60	50 l	8 m/s	3'000 rpm	60 mm	600 mm	up to 3.0 kW	2,4,5,9,10,11,12
PT(-C) 80	100 l	17 m/s	3'000 rpm	80 mm	800 mm	up to 4.0 kW	2,4,5,9,10,11,12
PT(-C) 120	400 l	25 m/s	3'000 rpm	120 mm	800 mm	up to 5.5 kW	2,4,5,9,10,11,12
PT(-C) 160	1'000 l	32 m/s	3'000 rpm	160 mm	800 mm	up to 7.5 kW	2,4,5,9,10,11,12
PT(-C) 250	4'000 l	17 m/s	1'500 rpm	250 mm	1000 mm	up to 22.0 kW	2,4,5,9,10,11,12
PT(-C) 330	8'000 l	16 m/s	1'000 rpm	330 mm	1500 mm	up to 45.0 kW	2,4,5,9,10,11,12
PT(-C) 350	10'000 l	17 m/s	750 rpm	350 mm	1500 mm	up to 55.0 kW	2,4,5,9,10,11,12

Further Descriptions / Options			
1	Batch Homogenizer for Pilot Plant	7	Quick Coupling type F for Dispersing Aggregates (also Dispersing Aggregates with coupling type B can be connected)
2	Batch Homogenizer for Production	8	Dispersing aggregate in EC design; easy disassembled and cleaned or sterilizing
3	Integrated speed regulation with digital display	9	Dispersing aggregates / shafts available as closed shaft tube design (standard)
4	Speed regulation by VSD available	10	Dispersing aggregates / shafts available as C (PT-C series) design for CIP
5	ATEX versions available (standard IIG-T3 - Zone 1 & Zone 2)	11	Available with mechanical seal systems (also gas lubricated version) for pressure and/or vacuum applications
6	PC connection and User Interface Software available	12	Special shaft lengths possible

Dispersing Generators for Pilot Plant (choice) - Types, Diameters, Applications

PTG ../2 standard generator rotor/stator with one teeth row each	PTG ../2M standard generator, rotor with knives, rotor/ stator with one teeth row each	PTG ../2W special W generator, rotor/stator with one teeth row each	PTG ../6 standard generator rotor/stator with three teeth rows each	BAG BIOTRONA® generator, blade rotor and stator with inclined slots	PTG ../DI special dissolver disk	PTG ../G special G-generator with mechanical seal
Ø 36, 40, 45, 50, 60 mm	Ø 36, 40, 45, 50, 60 mm	Ø 36, 40, 45, 50, 60 mm	Ø 45, 60 mm	Ø 36, 45 mm	Ø 53 mm	Ø 36, 40, 45, 50, 60 mm
- Dispersing and Mixing of solid particles into liquid - Preparing of samples for extraction and decomposition of organic material - Intensive mixing	- Dispersing and Mixing of solid particles into liquid - Preparing of samples for extraction and decomposition of organic material - Intensive mixing - Rotor with knives facilitate the processing of larger cell tissue samples or particles	- Dispersing of fibrous, stringy and brittle samples	- Making finest emulsions and suspensions - Mixes and reduces highly intensive solids into fluids - Gasses solutions - Separates fibers and cellular material into very small particles - Extractions	- High turbulent mixing with low shear forces - Fast dissolving and suspending of solids also at higher viscosity	- Fast mixing and homogenizing of solid material into fluids by means of a dissolving disk - Preparing highly viscous products	- Integrated single mechanical seal - Working under pressure and vacuum - Prevents foam buildup



POLYTRON® PT-C 120



POLYTRON® PT-BIA 120



POLYTRON® PT-C 350



PT-C SERIES



- **POLYTRON® PT-C series** is an enhanced *EasyClean* design where the stator tube is exchanged against stator rods. The design allows complete cleaning without disassembly and complies with CIP / SIP standards.

FC

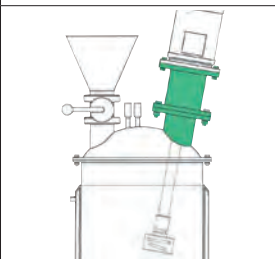

- Flange / Clamp connections for vessel mounting available

FS / WS / BS

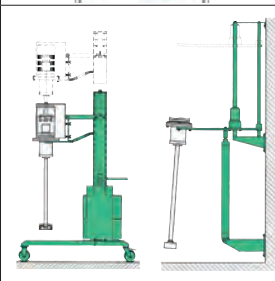

- Movable stand (left), fixed wall stand (right) or fixed ground stand
- Stroke: electric, hydraulic, pneumatic or manual

SS

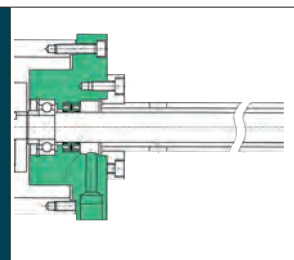

- Standard shaft seal

EW

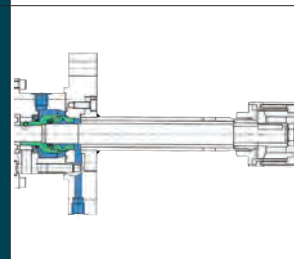

- Single mechanical seal versions including pressureless quench systems available for pressure and vacuum applications

DW

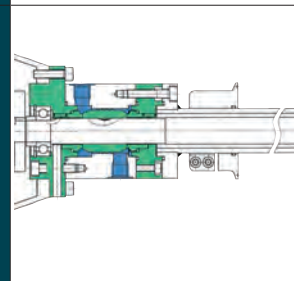

- Double mechanical seal versions including counterpressure sealing systems available for pressure and vacuum applications

Dispersing Generators for Production (choice) - Types, Diameters, Applications

PTG G-Type <i>standard generator, rotor and stator with one teeth row each</i>	PTG M-Type <i>standard generator, rotor and stator with one or two teeth rows each</i>	PTG F-Type <i>standard generator, rotor and stator with one or two teeth rows each</i>	PTG BIOTRONA®-Type <i>flash blender model, blade rotor and stator with inclined slots</i>	PTG TB-Type <i>high speed mixing model, turbine stirrer</i>	PTG DI-Type <i>high speed mixing model, dissolver disk</i>
Available for all series	Available for all series	Available for all series	Available for all series	Available for all series	Available for all series
<ul style="list-style-type: none"> - Dispersing, mixing and size reduction of coarse solids into liquid - Extractions - Mixing of fluids - Crushing of lumps - Intensive mixing 	<ul style="list-style-type: none"> - Producing of emulsions and suspensions with medium droplet and particle sizes - Wet milling of medium sized solids - Extractions - Acceleration of reactions - Intensive mixing - Crushing of lumps 	<ul style="list-style-type: none"> - Producing of emulsions and suspensions with fine droplet and particle sizes - Wet milling of fine solids - Cell pulping - Extractions - Accelerating of reactions - Fassing of fluids - De-agglomerations 	<ul style="list-style-type: none"> - High turbulent mixing with low shear forces - Fast dissolving and suspending of solids also at higher viscosities 	<ul style="list-style-type: none"> - Mixing and blending applications with smooth treatment also for higher viscosities 	<ul style="list-style-type: none"> - Mixing and blending applications also for higher viscosities

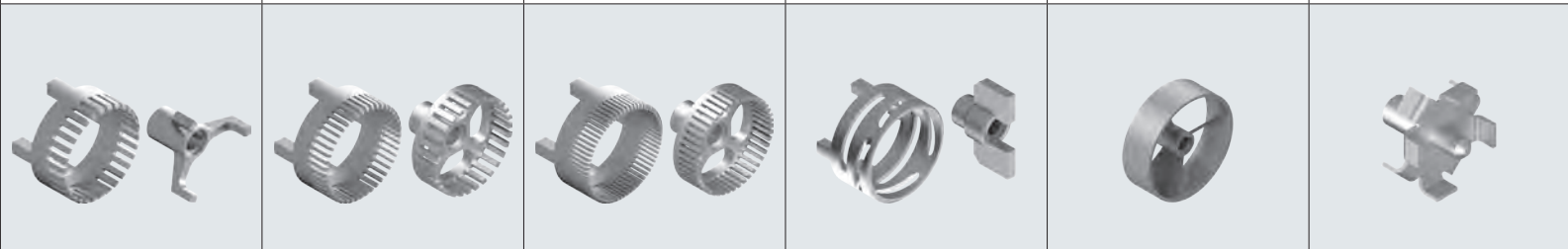

MEGATRON® MT machines are Inline homogenizers with a forced flow of the mixture through a working chamber. In the working chamber, the product will be processed by the rotor/stator dispersing generator(s).

With the series MEGATRON® MT and MEGATRON® MT-V KINEMATICA has set standards once more for the in-line homogenizing technology regarding efficiency, safe operation and long working life of the machinery for a broad application area within almost every industry field. The MEGATRON® family can be divided into three branches with high, medium and low shear rates. With decades of experience KINEMATICA can be your reliable partner and advisor on choosing the right level of shear rate for your application and product.

- Throughputs up to approx. 150'000 l/h
- High speed levels and tip speeds up to approx. 40 m/s
- Adjustable drive systems with power levels between approx. 1.5 kW and 110 kW
- Dispersing generators with rotor diameters between 30 mm and 350 mm; with fineness steps from coarse to medium to fine to super fine for reaching particle sizes within the lowest micrometer range respective the upper nano meter range depending on the properties of the treated products
- Vertically or horizontally installed single- or multi-staged working chambers
- Single or double acting mechanical sealing systems including supply systems
- Sterile versions, as well as CIP / SIP, 3A and ATEX versions can be supplied
- Product wetted parts made from high-alloyed stainless steel and sealing materials conform with the product

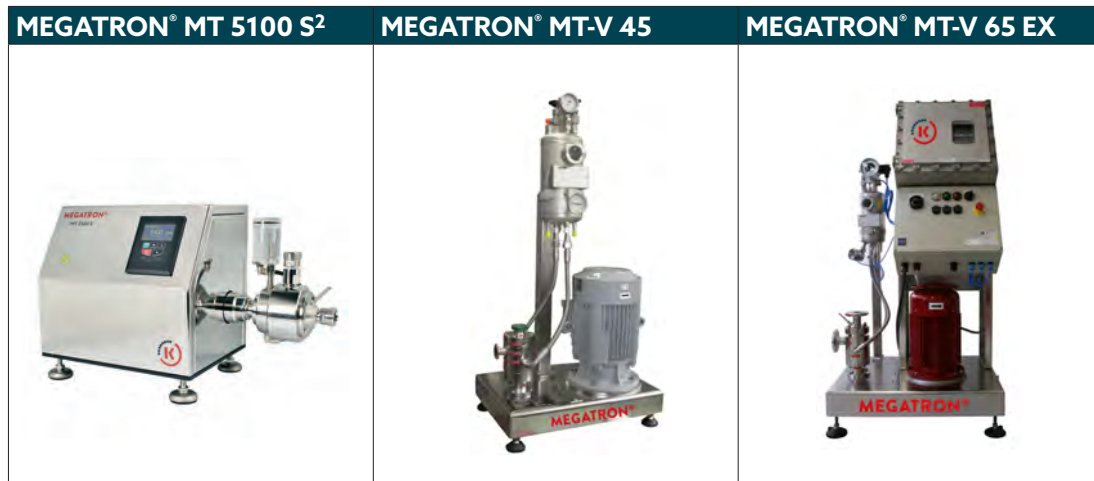

Model / Series	for throughputs up to	tip speed max.	rpm max.	Ø rotor	Power	Further Description, Options (see below)
MT 5100 S²	60 l/min	37 m/s	21'000 rpm	30-40 mm	1.5 kW	1,3,6,7,9,11,12
MT(-V) 45	3'000 l/h	28 m/s	12'000 rpm	45 mm	up to 4.0 kW	1,4,5,7,8,9,10,11,12
MT(-V) 65	4'500 l/h	34 m/s	10'000 rpm	65 mm	up to 11.0 kW	2,4,5,7,8,9,10,11,12
MT(-V) 95	15'000 l/h	40 m/s	8'000 rpm	95 mm	up to 22.0 kW	2,4,5,7,8,9,10,11,12
MT(-V) 160	35'000 l/h	30 m/s	3'000 rpm	160 mm	up to 37.0 kW	2,4,5,7,8,9,10,11,12
MT(-V) 220	50'000 l/h	16 m/s	3'000 rpm	220 mm	up to 55.0 kW	2,4,5,7,8,9,10,11,12
MT(-V) 300	90'000 l/h	24 m/s	1'500 rpm	300 mm	up to 75.0 kW	2,4,5,7,8,9,10,11,12
MT 330	128'000 l/h	26 m/s	1'500 rpm	330 mm	up to 90.0 kW	2,4,5,7,8,9,10,11,12
MT 350	150'000 l/h	18 m/s	1'000 rpm	350 mm	up to 110.0 kW	2,4,5,7,8,9,10,11,12

Further Descriptions / Options			
1	In-line Homogenizer for Pilot Plant	7	Working chamber available as single-stage design (one dispersing generator)
2	In-line Homogenizer for Production	8	Working chamber available as multi-stage design (up to three dispersing generators in series)
3	Integrated speed regulation with digital display	9	Working chamber as horizontal design (Standard)
4	Speed regulation by VSD available	10	Working chamber available as „vertical“ design (MT-V series) for CIP/SIP applications
5	ATEX versions available (standard IIG-T3 - Zone 1 & Zone 2)	11	Available with mechanical seal systems for pressure and/or vacuum applications
6	PC connection and User Interface Software available	12	Special design of working chamber and dispersing generators as well as different materials of construction possible

Dispersing Generators (choice) - Types, Diameters, Applications

MTG ../2G standard generator rotor/stator with one teeth row each	MTG ../4M standard generator, rotor and stator with two teeth rows each	MTG ../6F standard generator, rotor and stator with three teeth rows each	MTG ../6FF or ../8FF standard generator, rotor and stator with three or four teeth rows each	MTG ../6FV special generator, rotor and stator with three teeth rows each and reduced gaps
Ø 30 - 350 mm	Ø 30 - 350 mm	Ø 30 - 350 mm	Ø 30 - 350 mm	Ø 30 - 350 mm
<ul style="list-style-type: none"> - Dispersing and Mixing of coarse solid particles into liquid - Size reduction (wet milling) of coarse solids in liquid - Extractions - Mixing of fluids - Crushing of lumps - Intensive mixing 	<ul style="list-style-type: none"> - Producing of emulsions and suspensions with medium droplet and particle sizes - Wet milling of solids up to medium particle sizes - Extractions - Accelerating of reactions - Intensive mixing - Crushing of lumps 	<ul style="list-style-type: none"> - Producing of emulsions and suspensions with fine droplet and particle sizes - Wet milling of fine solids - Extractions - Accelerating of reactions - Gassing of fluids - Cell pulping - De-agglomerations 	<ul style="list-style-type: none"> - Producing of finest emulsions and suspensions with finest droplet and particle sizes - Wet milling of fine solids - Extractions - Accelerating of reactions - Gassing of fluids - Cell pulping - De-agglomerations - De-agglomerations 	<ul style="list-style-type: none"> - Producing of finest emulsions and suspensions with finest droplet and particle sizes - Extractions - Gassing of fluids - Cell pulping - De-agglomerations - Producing of finest Bio-fuels



MEGATRON® MT-V 95



MEGATRON® MT 300



MEGATRON® MT 350



MT-V SERIES		<ul style="list-style-type: none"> - Working chamber of a MEGATRON® MT-V series in-line homogenizer is arranged vertically. The product is fed from above and leaves the chamber on the side. The design allows complete draining and complies with CIP, SIP and 3A standards
MTO		<ul style="list-style-type: none"> - Working chamber without cooling / heating jacket - Shown as a single-stage working chamber with one dispersing generator
MTK		<ul style="list-style-type: none"> - Working chamber with cooling / heating jacket - Shown as a three working chamber with three dispersing generators in series

EW		<ul style="list-style-type: none"> - Single mechanical seal versions including pressureless quench systems available for pressure and vacuum applications
DW		<ul style="list-style-type: none"> - Double mechanical seal versions including counterpressure sealing systems available for pressure and vacuum applications
MBF/FBF		<ul style="list-style-type: none"> - Standard fixed base frame - Movable base frame

<p>H-Type generators special H-generators, rotor and stator with two teeth rows each and safety ring for high speed applications</p> <p>Available for all series (batch and in-line)</p> <ul style="list-style-type: none"> - Applications MTG ../4HG see MTG ../2G - Applications MTG ../4HM see MTG ../4M - Applications MTG ../4HF see MTG ../6F - Applications MTG ../4HS see MTG ../6FF - Other applications see standard generators 	<p>K-Type generators special generator, rotor and stator with one teeth row each, designed for optimal and smooth energy input</p> <p>Available for all series (batch and in-line)</p> <ul style="list-style-type: none"> - Producing of sauces, dressings, mayonnaise,... 	<p>K600-Type generators special hardened generator, rotor and stator with up to three teeth rows each</p> <p>Available for all series (batch and in-line)</p> <ul style="list-style-type: none"> - Applications with abrasive components - Material of the generator: tool steel K600 	<p>TiN-Type generators special titan-nitrated generator, rotor and stator with up to three teeth rows each</p> <p>Available for all series (batch and in-line)</p> <ul style="list-style-type: none"> - Applications with abrasive components - Material of the generator: 316L, coated
---	--	--	--

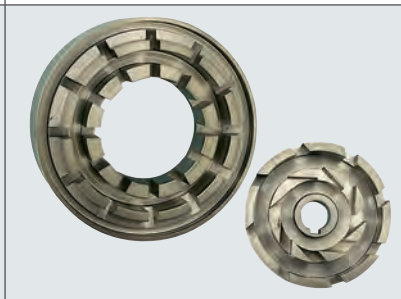

After several years of development KINEMATICA succeeded in introducing to the market an extremely efficient powder dispersing machine with the series MEGATRON MT-VPC / VPR.

Advantages of the newly developed system patented are above all, that due to a strongly improved suction capacity unwanted lumps can be avoided during powder sucking and wetting. This averts, for one thing, a plugging of the powder supply line and improves at the same time the homogeneous dispersing.

The generated high vacuum with a simultaneous high suction capacity is substantially independent of the liquid throughput and to a certain extent, also independent of the pressure at the outlet. This grants a dust-free incorporation into the liquid. It has been shown that the generatable suction capacity is sufficiently high that heavy powders, e.g. metal containing powders, can also be sucked in.

The new MEGATRON MT-VPC / VPR powder dispersing machine with its convective powder wetting system and a wide range of various dispersing generators substantially increases the number of application in the field of chemistry, pharma and food.

The series includes at present various sizes with a throughput related to water and depending on the dispersing generator used from approx. 1'000 l/h to 70'000 l/h.

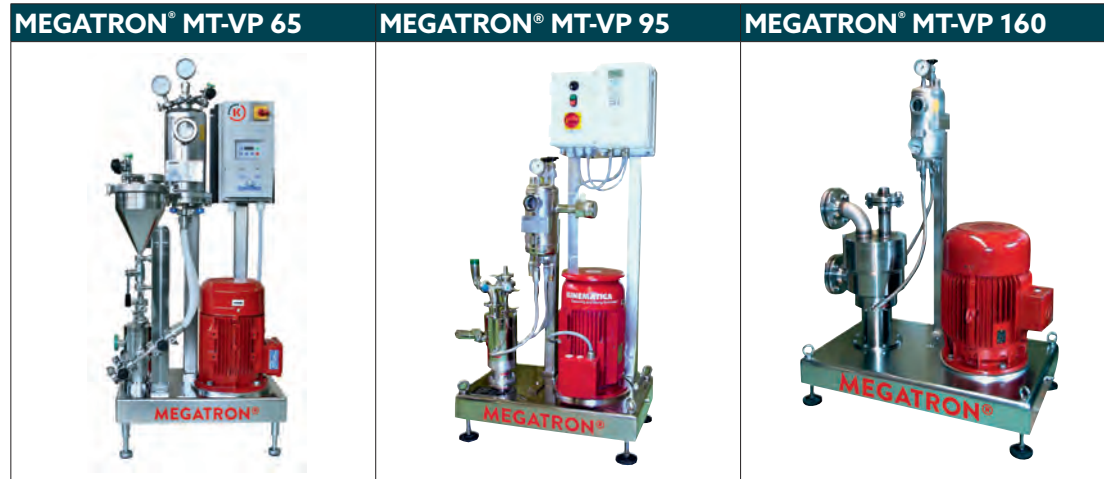

Model / Series	Throughput liquid max.	Suction capacity max.	tip speed max.	rpm max. (@50Hz)	Rotor-Ø	Drive Power
MT-VP 45	1000 l/h	70 kg/h	25 m/s	10'600 rpm	45 mm	up to 4.0 kW
MT-VP 65	3000 l/h	200 kg/h	25 m/s	7'700 rpm	65 mm	up to 11.0 kW
MT-VP 95	9'000 l/h	500 kg/h	25 m/s	5'200 rpm	95 mm	up to 22.0 kW
MT-VP 160	25'000 l/h	1'200 kg/h	25 m/s	3'000 rpm	160 mm	up to 37.0 kW
MT-VP 220	40'000 l/h	2'000 kg/h	25 m/s	2'300 rpm	220 mm	up to 55.0 kW
MT-VP 300	70'000 l/h	3'500 kg/h	25 m/s	1'700 rpm	300 mm	up to 75.0 kW



- MEGATRON® MT-VPC / VPR series are in-line processors combining in a two-stage working chamber an effective powder induction stage with a homogenizing / suspending stage
- MT-VP series are specially designed for powder induction of light to heavy powders and making finest suspensions
- Maximum generated vacuum at the powder induction is approx. 25 mbar
- Pressure up to 6 bar standard, higher possible
- Temperature up to 90 °C standard, higher possible
- Viscosity from aqueous up to paste-like

Dispersing Generators (choice) - Types, Diameters, Applications

MTG ../2G standard generator rotor/stator with one teeth row each	MTG ../4M standard generator, rotor and stator with two teeth rows each	MTG ../6F standard generator, rotor and stator with three teeth rows each	MTG ../6FF standard generator, rotor and stator with three teeth rows each	MTG ../6FV special generator, rotor and stator with three teeth rows each and reduced gaps	MTG ../P powder induction stage including housing and propeller
Ø 45 - 350 mm	Ø 45 - 300 mm	Ø 45 - 300 mm	Ø 45 - 300 mm	Ø 45 - 300 mm	Ø 45 - 300 mm
<ul style="list-style-type: none"> - Dispersing and Mixing of coarse solid particles into liquid - Size reduction (wet milling) of coarse solids in liquid - Extractions - Mixing of fluids - Crushing of lumps - Intensive mixing 	<ul style="list-style-type: none"> - Producing of emulsions and suspensions with medium droplet and particle sizes - Wet milling of solids up to medium particle sizes - Extractions - Accelerating of reactions - Intensive mixing - Crushing of lumps 	<ul style="list-style-type: none"> - Production of emulsions and suspensions with fine droplet and particle sizes - Wet milling of fine solids - Extractions - Accelerating of reactions - Gassing of fluids - Cell pulping - De-agglomerations 	<ul style="list-style-type: none"> - Producing of finest emulsions and suspensions with finest droplet and particle sizes - Wet milling of fine solids - Extractions - Accelerating of reactions - Gassing of fluids - Cell pulping - De-agglomerations 	<ul style="list-style-type: none"> - Producing of finest emulsions and suspensions with finest droplet and particle sizes - Extractions - Gassing of fluids - Cell pulping - De-agglomerations 	<ul style="list-style-type: none"> - Powder induction of light to heavy powders - Suitable for powders used in chemical, pharmaceutical, cosmetic, biochemical and food industries



The market of foamed products in the field of chemistry, pharma and food has heavily increased over the last few years. This not least because through the foaming process various product features can be adapted easier to modern trends and the quality and life time has considerably increased.

In collaboration with ETH Zürich KINEMATICA has brought to the market a new generation of foam processors with the series of MEGATRON® FM.

The striking feature of this series is the generation of smallest micro bubbles in the scale of 5 - 10 µm and its narrow distribution due to a brandnew rotor stator geometry.

The extremely effective foam processor MEGATRON® FM works constantly and is available in different versions for laboratory and pilot plant size for product and recipe development with a few liters throughput and in various sizes/performances for the production up to several 1000 liters throughput considering different working and environmental conditions.

We are happy to provide you with professional advice and to offer you all desirable accessories e.g. metering pumps with premixing container and mixer, cooling aggregate, process control.

Some typical applications in food are:

- foamed protein
- foamed dairy products
- foamed ice cream
- mousse-products
- foamed confectionary
- bread pastries
- foamed filling products
- and many more

MEGATRON® MT-FM 50



MEGATRON® MT-FM 200



Model / Series	Throughput liquid max.	Tip speed max.	rpm max.	Rotor-Ø	max. axial stages ..2 / ..6 design	Drive Power
MT-FM 30	10 l/h	24 m/s	12'000 rpm	30 mm	8 / 5	1.5 kW
MT-FM 50	40 l/h	26 m/s	10'000 rpm	50 mm	12 / 8	up to 7.5 kW
MT-FM 100	250 l/h	26 m/s	5'000 rpm	100 mm	18 / 12	up to 11.0 kW
MT-FM 150	700 l/h	24 m/s	3'000 rpm	150 mm	24 / 16	up to 22.0 kW
MT-FM 200	1'800 l/h	34 m/s	3'000 rpm	220 mm	30 / 20	up to 55.0 kW
MT-FM 300	4'000 l/h	24 m/s	1'500 rpm	300 mm	36 / 24	up to 90.0 kW

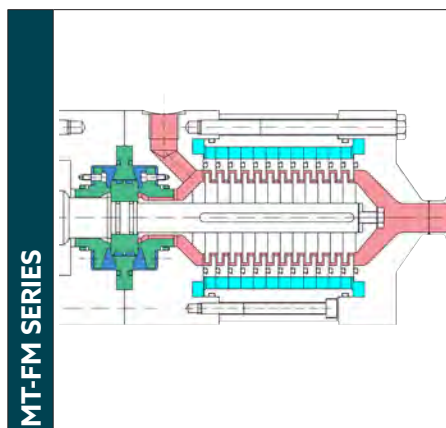

MT-FM SERIES

- MEGATRON® MT-FM series are axial flow through dispersing machines without pumping effects
- MT-FM series are specially designed for gas dispersions with bubble sizes < 20 µm at an optimum of homogenization
- Overruns up to several 100% are possible depending on the product
- Pressure up to 10 bar standard, higher possible
- Temperature up to 95 °C standard, higher possible
- Viscosity aqueous up to paste-like
- MT-FM series can also be used very successfully for intensive mixing / homogenizing of emulsions and suspensions

Dispersing Generators (choice) - Types, Diameters, Applications

FMG ..2 standard generator rotor/stator with one teeth row (stage) each, coarse teeth	FMG ../6 standard generator rotor/stator with one teeth row (stage) each, tine teeth	FMG/2 Monoblock standard generator rotor/stator with up to 36 teeth rows (stages) each, coarse teeth	FMG/6 Monoblock standard generator rotor/stator with up to 24 teeth rows (stages) each, fine teeth
Ø 30, 50 mm	Ø 30, 50 mm	Ø 100 - 300 mm	Ø 100 - 300 mm
<ul style="list-style-type: none"> - Foamed products with bubble sizes below 20 mm, depending on product - Foamed protein, milk products, ice-cream, confectionary, filling products - Mousse-products - Technical foams - Pharmaceutical / medical foams - Food foams, foamed sauces 	<ul style="list-style-type: none"> - Foamed products with bubble sizes below 10 mm, depending on product - Foamed protein, dairy products, ice-cream, confectionary, filling products - Mousse-products - Technical foams - Pharmaceutical / medical foams - Food foams, foamed sauces 	<ul style="list-style-type: none"> - Applications see FMG ..2 	<ul style="list-style-type: none"> - Applications see FMG ../6

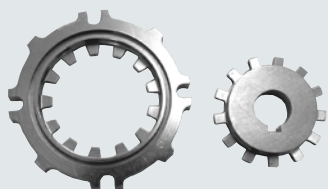

KINEMATICA offers also a range of complete homogenizing and mixing plants for different applications in the chemical, pharmaceutical, cosmetic and food industry - known under the brand name REACTRON®.

REACTRON® systems are designed to customers' specifications and consist normally of the following components: processing tank with POLYMIX® stirring system for macro mixing, POLYTRON® / MEGATRON® homogenizing system for down sizing and micro mixing, piping, process control and further specific equipment like vacuum pumps, heating / cooling thermostats.

REACTRON® systems are available for batch and semi-batch operation with volumes starting with 1 liter up to several 100 liters. They can be designed and manufactured according to customer and application specifications, incl. pressure / vacuum, CIP / SIP, clean room design and ATEX regulations.

Some application examples:

- Producing of creams, lotions, emulsions
- Pharmaceutical or cosmetic products
- Dispersing of fine solids into a liquid or molten phase
- Suspending of additives and solid polymers in mineral oils
- Producing of dairy products and diet food
- Polymerisations
- Extracting of enzymes from bio masses
- and many more



Model / Series	process vessel (**) working volume	suitable POLYTRON® Batch Homogenizer (*)	suitable MEGATRON® Inline Homogenizer (*)	suitable POLYMIX® Stirrer (*)
RT 1	1 l	PT 2500 E	MT 3100 S	PX-MT / PX-HT
RT 2	2 l	PT 10-35 GT	MT 3100 S	PX-MT / PX-HT
RT 5	5 l	PT 3100 D	MT 3100 S	PX-MT / PX-HT
RT 10	10 l	PT 3100 D	MT 3100 S	PX-MT / PX-HT
RT 15	15 l	PT 6100 D, PT 7100, PT-D 36-60	MT 3100 S / MT 5100 S	PX-MT / PX-HT
RT 40	40 l	PT(-C) 60	MT(-V) 45	PX-RW 0.35
RT 50	50 l	PT(-C) 80	MT(-V) 65	PX-RW 0.35
RT 100	100 l	PT(-C) 80	MT(-V) 65	PX-RW 0.55
RT 500	500 l	PT(-C) 120	MT(-V) 65	PX-RW 0.75
RT 1000	1'000 l	PT(-C) 160	MT(-V) 95	PX-RW 1.5

(*) The cited products shall only be understood as reference. The choice of the suitable Batch or In-line Homogenizer and the Stirrer depends also on the product specifications, customer specifications and the environmental and process conditions.

(**) Process vessel can be made from different materials including stainless steel 304, 316L, 316Ti, borosilicate glass or made from specific material on request. Material of construction depends also on product specifications, customer specifications and the environmental and process conditions.

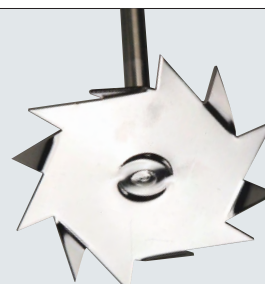

POLYMIX® Stirrers (choice) - Types, Diameters, Applications

Propeller Stirrer standard stirrer available with 3 or 4 blades, also PTFE coated or from different materials	Turbine Stirrer standard stirrer also PTFE coated or from different materials	Dissolver Stirrer standard stirrer	Anchor Stirrer standard stirrer available also with scrapers
Available in different sizes for all series	Available in different sizes for all series	Available in different sizes for all series	Available in different sizes for all series
<ul style="list-style-type: none"> - Stirrer with 3 blades. Favorable to flow. Top-down and bottom-up suction of the fluid. Low shear forces - Standard stirrer, 4 blades. Top-down suction of the fluid. Local shear forces. Generates axial flow in the vessel 	<ul style="list-style-type: none"> - Top-down suction of the fluid. Generates axial flow in the vessel. Low shear forces. 	<ul style="list-style-type: none"> - Radial flow. Top-down and bottom-up suction of the fluid. High turbulences, high shear forces, particle crushing. 	<ul style="list-style-type: none"> - Tangential flow, high shear rates in the border area. Few disposal at the vessel wall. Use at low speeds. Ideal for fluids with middle to high viscosity.



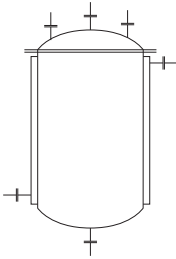
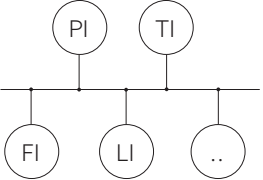
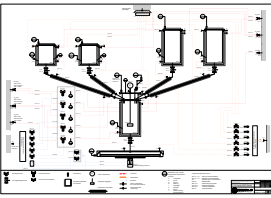
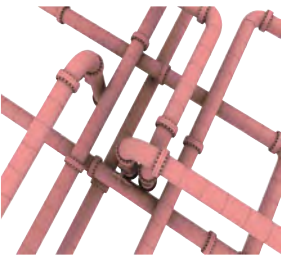

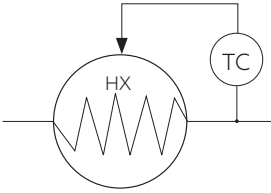
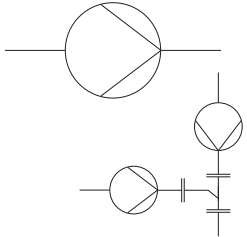
POLYMIX® Stirrers		<ul style="list-style-type: none"> - POLYMIX® range of stirrers can be used for stirring and macro-mixing tasks in combination with a REACTRON® process vessel - Different stirrer designs / sizes are available, like anchor stirrer, propeller stirrer, dissolver, ...
Process Vessels		<ul style="list-style-type: none"> - Process vessels as well as pre-mixing tanks can be designed to customer and product specifications - Multi-wall vessels with double jacket and isolation can be supplied - Lifting column for vessel cover can be supplied
Measuring Devices		<ul style="list-style-type: none"> - All necessary measuring devices for temperature, pressure, level, throughput, pH, viscosity, etc. can be supplied
PID		<ul style="list-style-type: none"> - KINEMATICA provides complete engineering services
Installation		<ul style="list-style-type: none"> - KINEMATICA provides complete installation services

Process Control		<ul style="list-style-type: none"> - Complete process control for manual, half-automatic and automatic operation can be engineered and supplied - SPS control systems can be supplied
Tempering		<ul style="list-style-type: none"> - It is often necessary to control the temperature; suitable tempering devices can be supplied
Pumping / Injecting		<ul style="list-style-type: none"> - It is often necessary to pump different components between vessels and to feed the homogenizers; suitable pumping devices as well as injectors can be supplied
DOCU / IQ / OQ		<ul style="list-style-type: none"> - KINEMATICA provides complete documentation services including IQ / OQ
Service		<ul style="list-style-type: none"> - KINEMATICA provides complete after sales services



Our mission. Your solution.

Homogenizing perfected: for every industry.

Das breite Portfolio der Kinematica kann nahezu sämtliche Dispergieranwendungen im Bereich der Chemie-, Pharma- Kosmetik-, Lebensmittel- und Biotechnikindustrie abdecken. Innovative Pulverinduktionssysteme, Lösungen für vollständig sterile Umgebungen, ATEX-konforme Auslegungen sowie die stufenlose Skalierbarkeit von Pilotanlagen bis hin zu hochtechnischen Produktionsanlagen sind nur einige der Beispiele, welche Kinematica bieten kann.

Mit professioneller Beratung, einem umfassenden Engineering-Angebot und modernster Technologie können Prozesse wie Homogenisieren, Emulgieren, Suspendieren, Nassmahlen, Desagglomerieren, Schäumen, Mischen oder Rühren bei gleichzeitiger Partikelzerkleinerung bis in den Mikro-/Nanometerbereich effizient umgesetzt werden. Dabei sorgen das patentierte Design und die innovativen Geometrien unserer Aggregate/Generatoren für perfekte Ergebnisse mit engen Teilchengrößenverteilungen für feinste Emulsionen, Suspensionen und Schaumdispersionen.



PHARMA



CHEMICAL



COSMETICS



FOOD



LIFE SCIENCE



HEADQUARTERS

Kinematica AG
Werkstrasse 7 c-d
CH-6102 Malters
Switzerland

Phone +41 41 259 65 65
Fax +41 41 259 65 75

info@kinematica.ch
kinematica.ch

EUROPE

Kinematica GmbH / Germany / Phone +49 7634 504 800 0 / info@kinematica.de

NORTH AND SOUTH AMERICA

Kinematica, Inc. / USA / Phone +1 631 750 6653 / info@kinematica-inc.com

CENTRAL AND EASTERN EUROPE

Kinematica AG / Switzerland / Phone +41 41 259 65 65 / info@kinematica.ch

ASIA AND GREATER CHINA

Kinematica Asia Limited / Hong Kong / Phone +852 249 769 65 / info@kinematica.net